



Installation Manual

Please read this manual carefully before installing and using the modules.

It is the great honor to provide you with our PV modules. In order to enable the PV module to be installed correctly and to generate electric power properly, please read the following operation instruction carefully.

Warning:

1. The maximum load test on the module surface must not exceed 5400Pa. For our modules, designed mechanical load of front face is 3600Pa and safety factor is 1.5; designed mechanical load of back face is 2400Pa and safety factor is 1.5。
2. Artificially concentrated sunlight shall not be directed on the module or panel.
3. Safety class is class II.
4. If the module is to be mounted to a roof of a building, the assembly is to be mounted over a fire resistant roof covering rated for the application for the non - integral module. Any slope less than 127mm/300mm required to maintain a fire class rating. It is stated that the assembly is to be mounted over a fire resistant roof covering rated for the fire class C application. The fire class rating of modules is Class C.
5. Modules rated for use in this application class may be used in systems operating at greater than 50V DC or 240W, where general contact access is anticipated. Modules qualified for safety through this part of IEC61730 and IEC61730-2 and within this application class are considered to meet the requirements for safety class II.
6. Under normal conditions, a photovoltaic module is likely to experience conditions

E-mail: info@more-energy.net www.more-energy.net

Adresse: Fürtherstr. 38, 90429 Nürnberg, Germany

Hotline/WhatsApp: +49 15 225 20 30 30



that produce more current and/or voltage than reported at standard test conditions. Accordingly, the value of Isc and Voc marked on this module should be multiplied by of 1.25 when determining component voltage ratings, conductor current ratings, fuse sizes, and size of controls connected to the PV output.

7. Do not touch live terminals with bare hands. Use insulated tools for electrical connections.

8. To reduce the risk of electrical shock or burns, modules may be covered with an opaque material during installation to avoid shocks or burns.

9. The installation work of the PV array can only be done under the protection of sun-sheltering covers or sunshades and only qualified person can install or perform maintenance work on this module.

10. Follow the battery manufacture's recommendations if batteries are used with modules.

11. All instructions should be read and understood before attempting to install, wire, operate and maintain the module.

12. If instructions are provided allowing modules to be installed in parallel electrically, the installation instructions shall specify that each module (or series string of modules so connected) shall be provided with the maximum series fuse.

13. Recommended maximum series/parallel module configurations;

$[(1500V/(1.25*Voc)]/[fuse\ rating/Isc+1]$.

Unpacking

E-mail: info@more-energy.net www.more-energy.net

Adresse: Fürtherstr. 38, 90429 Nürnberg, Germany

Hotline/WhatsApp: +49 15 225 20 30 30



After the PV module has been shipped to the installation site all of the parts should be unpacked properly with care.

Caution: The condign environment for unpacking the modules and all other apparatus should be proofed against dampness and rainfall.

Preparation before Installation:

1. Optical check before installation, to make sure there is no bug in the packing and junction box as well as the surface of module.

2. Check the series number

3. Check the solar cell modules with irradiance of more than $600\text{W}/\text{m}^2$ and get the voltage. In case the voltage is ZERO, it should NOT be installed and please contact the supplier.

4. Tools & Material for Installation

① Screwdriver

② Use at minimum 4 clamps to attach a module to the mounting rails. Unless the clamps are used on the first module or the last module of a row of the PV modules, one clamp fixes two PV modules. The clamps should not contact the front glass of modules, and must not deform the frames. Be sure to avoid shadowing effects from the module clamps.

③ Each clamp matches with a set of a screw, a nut and two washer.

④ The users should design and build metallic bracket for installing and bearing the weight of the PV modules. The brackets are specially designed for users' installation

E-mail: info@more-energy.net www.more-energy.net

Adresse: Fürtherstr. 38, 90429 Nürnberg, Germany

Hotline/WhatsApp: +49 15 225 20 30 30



places such as the open land or on the roof of houses.

Caution: To avoid damage from flooding and other unpredictable events, and avoid heavy impact. To design a gradient angle facing the sun radiation direction in order to insure the full sunshine receives as much as possible.

Installation environment conditions and site selection

1. The environmental conditions applicable to the installation of PV modules are as follows: The recommended operating temperature ranges from -20°C to $+50^{\circ}\text{C}$, and the limit operating temperature ranges from -40°C to $+85^{\circ}\text{C}$.
2. PV modules should be installed as far as possible in the year-round area without shade. Do not install PV modules where they may be flooded.
3. When installing solar modules on a roof, a safe working area must also be left between the edge of the roof and the outer edge of the PV modules array. When the modules are piled on the roof, the load of the roof should be checked, and the construction organization plan in accordance with the requirements of the code should be formulated.
4. When used in areas with high wind pressure and snow pressure, support fixed structures should be designed in strict accordance with local design specifications to ensure that the external load does not exceed the mechanical strength limit that the modules can bear.
5. Modules should not be immersed in water or in an environment with water (pure water or salt water) for a long time (such as fountains, waves, etc.). There is a risk of

E-mail: info@more-energy.net www.more-energy.net

Adresse: Fürtherstr. 38, 90429 Nürnberg, Germany

Hotline/WhatsApp: +49 15 225 20 30 30



corrosion if the modules is exposed to salt spray (i.e., Marine environment) or sulfur (i.e., sulfur source, volcano). It is not recommended to install PV modules within 0.1km of the Marine environment. Install salt spray resistant PV modules between 0.1km and 1km, and make anti-corrosion treatment for installation parts.

Installation environment conditions and site selection

1. The environmental conditions applicable to the installation of PV modules are as follows: The recommended operating temperature ranges from -20°C to $+50^{\circ}\text{C}$, and the limit operating temperature ranges from -40°C to $+85^{\circ}\text{C}$.
2. PV modules should be installed as far as possible in the year-round area without shade. Do not install PV modules where they may be flooded.
3. When installing solar modules on a roof, a safe working area must also be left between the edge of the roof and the outer edge of the PV modules array. When the modules are piled on the roof, the load of the roof should be checked, and the construction organization plan in accordance with the requirements of the code should be formulated.
4. When used in areas with high wind pressure and snow pressure, support fixed structures should be designed in strict accordance with local design specifications to ensure that the external load does not exceed the mechanical strength limit that the modules can bear.
5. Modules should not be immersed in water or in an environment with water (pure water or salt water) for a long time (such as fountains, waves, etc.). There is a risk of

E-mail: info@more-energy.net www.more-energy.net

Adresse: Fürtherstr. 38, 90429 Nürnberg, Germany

Hotline/WhatsApp: +49 15 225 20 30 30



corrosion if the modules is exposed to salt spray (i.e., Marine environment) or sulfur (i.e., sulfur source, volcano). It is not recommended to install PV modules within 0.1km of the Marine environment. Install salt spray resistant PV modules between 0.1km and 1km, and make anti-corrosion treatment for installation parts.

Installation and operation

1. Systems should be installed by qualified personnel only and at least two persons. The system involves electricity, and can be dangerous if the personnel are not familiar with the appropriate safety procedures.
2. Do not step on the module.
3. Although modules are quite rugged, the glass can be broken (and the module will no longer work properly) if it is dropped or hit by tools or other objects.
4. Put the PV modules on the frames and connect each two modules with clamps. The center line of clamps must be on a straight line at 5cm above or below the mounting hole. Install the screw, gasket and nut in turn, tighten the screws, and firmly combine the modules and frames. All the screw caps should be finished on the frame together firmly. The module frame is made of anodized aluminum, and therefore corrosion can occur if the module is subject to a salt-water environment with contact to a rack of another type of metal. (Electrolysis Corrosion) if required. PVC or stainless steel washers can be placed between the solar module frame and support structure to prevent this corrosion.

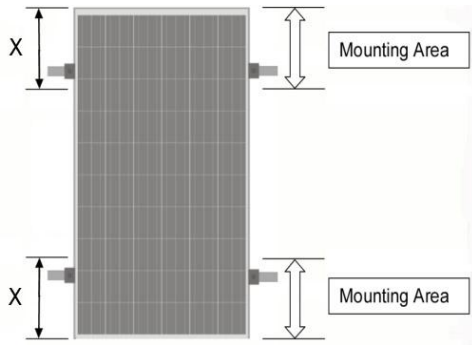

Module Type	X/mm
G12-132	354 ~ 404
G12-120	248 ~ 298
M10-144	301 ~ 351
M6-132/M10-120	124 ~ 174
M6-120/M10-108	265 ~ 315
M6-144/M10-132/G1-60/SG1-120	208 ~ 258
G1-54/G1-36	191 ~ 241
G12-108/G1-72/SG1-144/G1-48	140 ~ 190

portrait orientation

5. At least 4 clamps are required on each module, two clamps should be attached on each long side of the module (for portrait orientation). Depending on the local Snowstorm Weather conditions, additional clamps may be required to ensure that the modules can withstand loads. The applied torque should refer to mechanical design standards according to the bolts used by customers.

The recommended standoff height is 20 cm. If other mounting means are employed this may affect the TUV Listing or the fire class ratings. The mounting tilt angle should be in accordance with local condition.

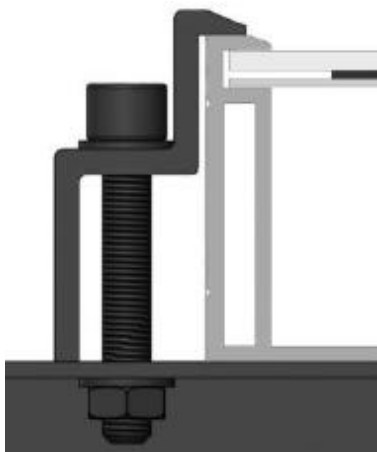

End Clamp installation

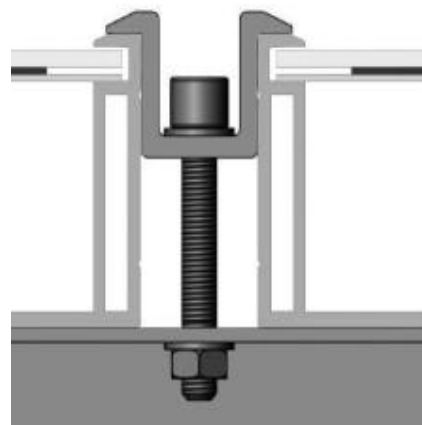

Middle Clamp installation

The module has been evaluated by TUV for mounting using clamps.

6. Way of grounding:

All module frames should be grounded for safety. The grounding connections between modules must be approved by a qualified electrician, the grounding itself must be made by a qualified electrician. The ground wire should be at least the same size as the electrical conductors, ground wires no less than 4mm^2 are recommended.

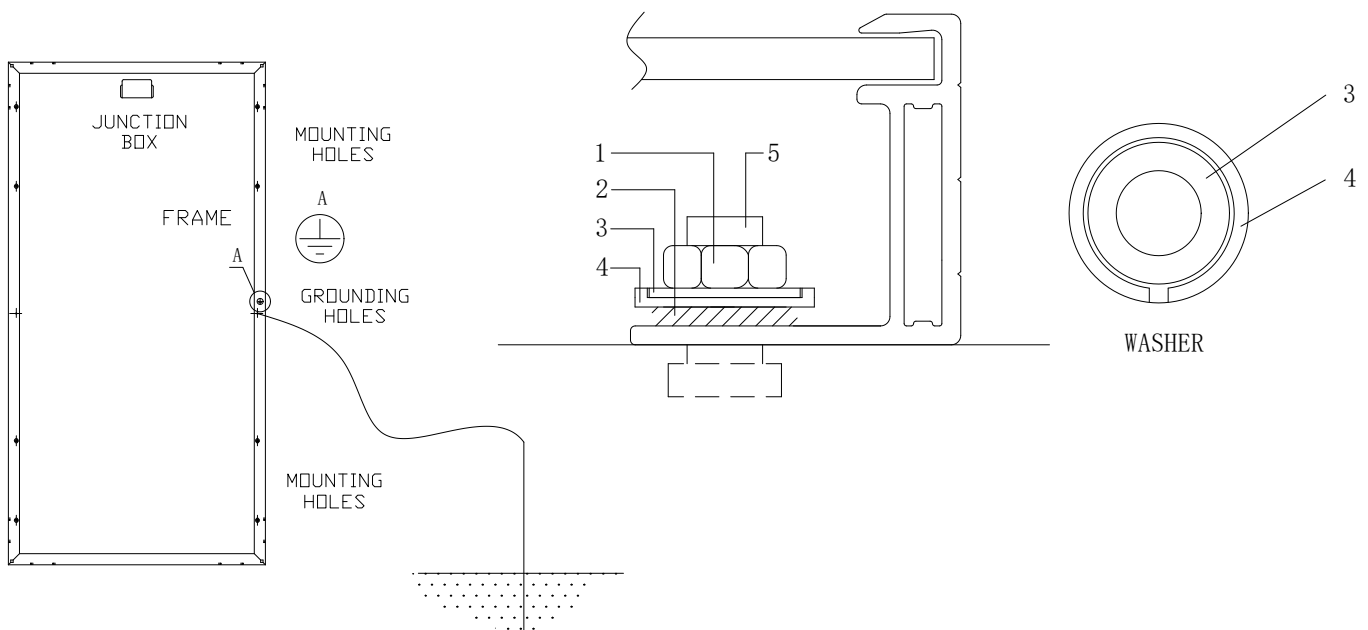

1. Stainless steel M4 nut
2. Stainless steel serrated washer
3. Stainless steel washer
4. Stainless steel cupped-shape washer



5. Stainless steel M4 t-head bolt

7. Module support structures that are to be used to support modules should be wind rated and approved for use by the appropriate local and civil codes prior to installation.

8. When solar modules are used to charge batteries, the battery must be installed in a manner, which will protect the performance of the system and the safety of its users.

Follow the battery manufacturer's guidelines concerning installation, operation and maintenance recommendations. In general, the battery (or battery bank) should be away from the main flow of people and animal traffic. Select a battery site that is protected from sunlight, rain, snow, debris, and is well ventilated. Most batteries generate hydrogen gas when charging, which can be explosive. Do not light matches or create sparks near the battery bank. When a battery is installed outdoors, it should be placed in an insulated and ventilated battery case specifically designed for the purpose.

9. In most applications, PV modules should be installed in a location where they will receive maximum sunlight throughout the year. In the Northern Hemisphere, the modules should typically face south, and in the Southern Hemisphere, the modules should typically face north. Modules facing 30 degrees away from true South (or north) will lose approximately 10 to 15 percent of their power output. If the module faces 60 degrees away from true South (or North), the power loss will be 20 to 30 percent.

When choosing a site, avoid trees, buildings or obstructions, which could cast shadows on the solar.

Wiring and Connection:

E-mail: info@more-energy.net www.more-energy.net

Adresse: Fürtherstr. 38, 90429 Nürnberg, Germany

Hotline/WhatsApp: +49 15 225 20 30 30



1. Before this procedure, please read the operation instructions of the PV control system carefully.

2. Partial shading of an individual module can cause a reverse voltage across the shaded module. Current is then forced through the shaded area by the other modules.

When a bypass diode is wired in parallel with the series string, the forced current will flow through the diode and bypass the shaded module, thereby minimize module heating and array current losses. Diodes are used as bypass diodes.

3.

Series	The number of series connection	The number of parallel connection
ME380G1-72 / ME380G1B-72	24	2
ME315G1-60 / ME315G1B-60	29	2
ME285G1-54 / ME285G1B-54	32	2
ME250G1-48 / ME250G1B-48	37	2
ME190G1-36 / ME190G1B-36	48	2
ME405SG1-144 / ME405SB-144	24	2
ME340SG1-120 / ME340SB-120	28	2
ME445M6-144 / ME445M6B-144	24	2
ME405M6-132 / ME405M6B-132	26	2
ME370M6-120 / ME370M6B-120	29	2
ME540M10-144 / ME540M10B-144	24	2



ME495M10-132 / ME495M10B-132	26	2
ME450M10-120 / ME450M10B-120	28	2
ME405M10-108 / ME405M10B-108	32	2
ME650G12-132 / ME650G12B-132	26	2
ME590G12-120 / ME590G12B-120	29	2
ME530G12-108 / ME530G12B-108	32	2

4. Make wiring by Multi-connecting cables between the PV modules in series or parallel connection, which is determined by user's configuration requirement for system power, current and voltage.

5. Open the connection box of the control system and connect the cabled from the PV arrays to the connection box in accordance with the installation indication of the PV control systems.

6. All module frames and mounting racks must be properly grounded in accordance with local and national electrical codes.

7. Follow the requirements of applicable local and national electrical codes.

8. Cables and Wiring

These junction boxes have been designed to be easily interconnected in series for their well-connected cable and the connector with IP68 protection grade. Each Modules has two single-conductor wires, one positive and one negative, which are pre-wired inside the junction box. The connectors at the opposite end of these wires allow easy series connection of adjacent Modules by firmly inserting the positive connector of a Module



into the negative connector of an adjacent Module until the connector is fully seated. Use field wiring with suitable cross-sectional areas that are approved for use at the maximum short-circuit current of the Modules. The minimum wire size should be 4mm².

9. Connectors

Keep connectors dry and clean, and ensure that connector caps are hand tight before connecting the Modules. Do not attempt making an electrical connection with wet, soiled, or otherwise faulty connectors. Avoid sunlight exposure and water immersion of the connectors. Avoid connectors resting on the ground or roof surface.

Faulty connections can result in arcs and electrical shock. Check that all electrical connections are securely fastened. Make sure that all locking connectors are fully engaged and locked. Besides, the connector should be mated with its original female or male connector of the same supplier.

For the detailed parameter, see the below list:

Type	Manufacture	System Voltage	Rated Current	Temperature Rating
05-8	Zhejiang Renhe Photovoltaic Technology Co.,Ltd	DC 1500V	30A	-40°C to +85°C
PV-CY03L	Zhejiang Chuangyuan Photovoltaic Technology Co.,Ltd	DC 1500V	30A	-40°C to +85°C
RHC2xyzu	Zhejiang Renhe Photovoltaic Technology Co.,Ltd	DC 1500V	35A	-40°C to +85°C
QC4.10-cd	QC Solar (Suzhou) Corporation	DC 1500V	41A	-40°C to +85°C

10. Bypass Diodes

The junction boxes used with Modules contain bypass diodes wired in parallel with the PV cell strings. In the case of partial shading, the diodes bypass the current generated



by the non-shaded cells, thereby limiting Modules heating and performance losses.

Bypass diodes are not over-current protection devices.

For the detailed parameter, see the below list:

Type	Manufacture	Rated current
PS4025	Yangzhou Yangjie Electronic TechnologyCo.,Ltd	15A
FMK4530T	ChangZhou Star Sea Electronics Co.,Ltd.	20A
GF30SQ045	Yangzhou Yangjie Electronic TechnologyCo.,Ltd	15A
FMK5040D	Zhejiang Renhe Photovoltaic Technology Co.,Ltd	25A
QCMK4045	QC Solar (Suzhou) Corparation	25A
QCMK5045	QC Solar (Suzhou) Corparation	30A

Maintenance and Care:

A built up of dust or dirt on the module(s) front face will result in a decreased energy output. Clean the panel(s) preferably once per annum if possible (dependant on site conditions) using a soft cloth dry or damp, as necessary.

Never use abrasive material under any circumstances.

Examine the PV module(s) for signs of deterioration. Check all wiring for possible rodent damage, weathering and that all connections are tight and corrosion free. Check electrical leakage to ground.

Check fixing screws and mounting brackets are tight, adjust and tighten as necessary.



Date sheet for all module types of the family

Working Conditions	Mono Series
Pmax Temperature Coefficient	-0.381 %/°C
Voc Temperature Coefficient	-0.276 %/°C
Isc Temperature Coefficient	+0.046 %/°C
Operating Temperature	-40~+85 °C
NMOT	45±2 °C
Maximum System Voltage	1500V
Maximum Series Fuse	30A

ME380G1-72 / ME380G1B-72 Series:

Parameters	ME340G1-72/ ME340G1B-72	ME345G1-72/ ME345G1B-72	ME350G1-72/ ME350G1B-72	ME355G1-72/ ME355G1B-72	ME360G1-72/ ME360G1B-72	ME365G1-72/ ME365G1B-72	ME370G1-72/ ME370G1B-72	ME375G1-72/ ME375G1B-72
Peak power Pm(W)	340±3%	345±3%	350±3%	355±3%	360±3%	365±3%	370±3%	375±3%
Open circuit voltage Voc(V)	47.31±2%	47.56±2%	47.78±2%	47.97±2%	48.07±2%	48.24±2%	48.37±2%	48.52±2%
Short circuit current Isc(A)	9.64±2%	9.68±2%	9.72±2%	9.76±2%	9.81±2%	9.86±2%	9.94±2%	10.01±2%

E-mail: info@more-energy.net www.more-energy.net

Adresse: Fürtherstr. 38, 90429 Nürnberg, Germany

Hotline/WhatsApp: +49 15 225 20 30 30



Max. power voltage Vmp(V)	37.40	37.79	38.13	38.46	38.79	39.12	39.32	39.56
Max. power current Imp(A)	9.09	9.13	9.18	9.23	9.28	9.33	9.41	9.48
Parameters	ME380G1-72/ ME380G1B-72	ME385G1-72/ ME385G1B-72	ME390G1-72/ ME390G1B-72	ME395G1-72/ ME395G1B-72	ME400G1-72/ ME400G1B-72			
Peak power Pm(W)	380±3%	385±3%	390±3%	395±3%	400±3%			
Open circuit voltage Voc(V)	48.69±2%	48.94±2%	49.15±2%	49.41±2%	49.68±2%			
Short circuit current Isc(A)	10.08±2%	10.13±2%	10.19±2%	10.26±2%	10.33±2%			
Max. power voltage Vmp(V)	39.83	40.15	40.33	40.60	40.86			
Max. power current Imp(A)	9.54	9.59	9.67	9.73	9.79			

ME315G1-60 / ME315G1B-60 Series:

Parameters	ME285G1-60/ ME285G1B-60	ME290G1-60/ ME290G1B-60	ME295G1-60/ ME295G1B-60	ME300G1-60/ ME300G1B-60	ME305G1-60/ ME305G1B-60	ME310G1-60/ ME310G1B-60	ME315G1-60/ ME315G1B-60
Peak power Pm(W)	285±3%	290±3%	295±3%	300±3%	305±3%	310±3%	315±3%
Open circuit voltage Voc(V)	39.62±2%	39.85±2%	40.01±2%	40.24±2%	40.55±2%	40.81±2%	41.13±2%
Short circuit current Isc(A)	9.61±2%	9.70±2%	9.79±2%	9.86±2%	9.95±2%	10.06±2%	10.13±2%
Max. power voltage Vmp(V)	31.49	31.76	32.03	32.33	32.55	32.70	33.02
Max. power current Imp(A)	9.05	9.13	9.21	9.28	9.37	9.48	9.54
Parameters	ME320G1-60/ ME320G1B-60	ME325G1-60/ ME325G1B-60	ME330G1-60/ ME330G1B-60				
Peak power Pm(W)	320±3%	325±3%	330±3%				
Open circuit voltage Voc(V)	41.47±2%	41.72±2%	41.94±2%				

E-mail: info@more-energy.net www.more-energy.net

Adresse: Fürtherstr. 38, 90429 Nürnberg, Germany

Hotline/WhatsApp: +49 15 225 20 30 30



Short circuit current Isc(A)	10.21±2%	10.28±2%	10.35±2%				
Max. power voltage Vmp(V)	33.23	33.47	33.67				
Max. power current Imp(A)	9.63	9.71	9.80				

ME285G1-54 / ME285G1B-54 Series:

Parameters	ME255G1-54/ ME255G1B-54	ME260G1-54/ ME260G1B-54	ME265G1-54/ ME265G1B-54	ME270G1-54/ ME270G1B-54	ME275G1-54/ ME275G1B-54	ME280G1-54/ ME280G1B-54	ME285G1-54/ ME285G1B-54
Peak power Pm(W)	255±3%	260±3%	265±3%	270±3%	275±3%	280±3%	285±3%
Open circuit voltage Voc(V)	35.73±2%	35.94±2%	36.14±2%	36.38±2%	36.63±2%	36.91±2%	37.07±2%
Short circuit current Isc(A)	9.71±2%	9.80±2%	9.91±2%	10.01±2%	10.12±2%	10.24±2%	10.35±2%
Max. power voltage Vmp(V)	27.96	28.23	28.49	28.66	28.89	29.05	29.23
Max. power current Imp(A)	9.12	9.21	9.30	9.42	9.52	9.64	9.75
Parameters	ME290G1-54/ ME290G1B-54	ME295G1-54/ ME295G1B-54	ME300G1-54/ ME300G1B-54				
Peak power Pm(W)	290±3%	295±3%	300±3%				
Open circuit voltage Voc(V)	37.24±2%	37.45±2%	37.65±2%				
Short circuit current Isc(A)	10.45±2%	10.55±2%	10.66±2%				
Max. power voltage Vmp(V)	29.38	29.59	29.82				

E-mail: info@more-energy.net www.more-energy.net

Adresse: Fürtherstr. 38, 90429 Nürnberg, Germany

Hotline/WhatsApp: +49 15 225 20 30 30



Max. power current Imp(A)	9.87	9.97	10.06				
---------------------------	------	------	-------	--	--	--	--

ME250G1-48 / ME250G1B-48 Series:

Parameters	ME230G1-48/ ME230G1B-48	ME235G1-48/ ME235G1B-48	ME240G1-48/ ME240G1B-48	ME245G1-48/ ME245G1B-48	ME250G1-48/ ME250G1B-48	ME255G1-48/ ME255G1B-48	ME260G1-48/ ME260G1B-48	ME265G1-48/ ME265G1B-48
Peak power Pm(W)	230±3%	235±3%	240±3%	245±3%	250±3%	255±3%	260±3%	265±3%
Open circuit voltage Voc(V)	31.67±2%	31.77±2%	31.94±2%	32.12±2%	32.34±2%	32.54±2%	32.71±2%	32.93±2%
Short circuit current Isc(A)	9.76±2%	9.89±2%	10.01±2%	10.14±2%	10.25±2%	10.36±2%	10.48±2%	10.60±2%
Max. power voltage Vmp(V)	25.11	25.27	25.50	25.68	25.91	26.10	26.26	26.47
Max. power current Imp(A)	9.16	9.30	9.41	9.54	9.65	9.77	9.90	10.01

ME190G1-36 / ME190G1B-36 Series:

Parameters	ME170G1-36/	ME175G1-36/	ME180G1-36/	ME185G1-36/	ME190G1-36/	ME195G1-36/	ME200G1-36/
------------	-------------	-------------	-------------	-------------	-------------	-------------	-------------

E-mail: info@more-energy.net www.more-energy.net

Adresse: Fürtherstr. 38, 90429 Nürnberg, Germany

Hotline/WhatsApp: +49 15 225 20 30 30



	ME170G1B-36	ME175G1B-36	ME180G1B-36	ME185G1B-36	ME190G1B-36	ME195G1B-36	ME200G1B-36
Peak power Pm(W)	170±3%	175±3%	180±3%	185±3%	190±3%	195±3%	200±3%
Open circuit voltage Voc(V)	23.74±2%	24.05±2%	24.21±2%	24.48±2%	24.72±2%	24.95±2%	25.23±2%
Short circuit current Isc(A)	9.62±2%	9.75±2%	9.93±2%	10.11±2%	10.24±2%	10.38±2%	10.51±2%
Max. power voltage Vmp(V)	18.74	19.06	19.23	19.39	19.65	19.88	20.14
Max. power current Imp(A)	9.07	9.18	9.36	9.54	9.67	9.81	9.93

ME405SG1-144 / ME405SB-144 Series:

Parameters	ME380SG1-144/ ME380SB-144	ME385SG1-144/ ME385SB-144	ME390SG1-144/ ME390SB-144	ME395SG1-144/ ME395SB-144	ME400SG1-144/ ME400SB-144	ME405SG1-144/ ME405SB-144
Peak power Pm(W)	380±3%	385±3%	390±3%	395±3%	400±3%	405±3%
Open circuit voltage Voc(V)	48.69±2%	48.94±2%	49.15±2%	49.41±2%	49.68±2%	49.81±2%
Short circuit current Isc(A)	10.08±2%	10.13±2%	10.19±2%	10.26±2%	10.33±2%	10.41±2%
Max. power voltage Vmp(V)	39.83	40.15	40.33	40.60	40.86	41.08
Max. power current Imp(A)	9.54	9.59	9.67	9.73	9.79	9.86
Parameters	ME410SG1-144/ ME410SB-144	ME415SG1-144/ ME415SB-144	ME420SG1-144/ ME420SB-144	ME425SG1-144/ ME425SB-144		
Peak power Pm(W)	410±3%	415±3%	420±3%	425±3%		
Open circuit voltage Voc(V)	49.95±2%	50.03±2%	50.30±2%	50.59±2%		
Short circuit current Isc(A)	10.49±2%	10.57±2%	10.65±2%	10.72±2%		
Max. power voltage Vmp(V)	41.16	41.29	41.50	41.75		
Max. power current Imp(A)	9.96	10.05	10.12	10.18		

E-mail: info@more-energy.net www.more-energy.net
 Adresse: Fürtherstr. 38, 90429 Nürnberg, Germany
 Hotline/WhatsApp: +49 15 225 20 30 30



ME340SG1-120 / ME340SB-120 Series:

Parameters	ME320SG1-120 / ME320SB-120	ME325SG1-120 / ME325SB-120	ME330SG1-120 / ME330SB-120	ME335SG1-120 / ME335SB-120	ME340SG1-120 / ME340SB-120	ME345SG1-120 / ME345SB-120	ME350SG1-120 / ME350SB-120	ME355SG1-120 / ME355SB-120
Peak power Pm(W)	320±3%	325±3%	330±3%	335±3%	340±3%	345±3%	350±3%	355±3%
Open circuit voltage Voc(V)	41.47±2%	41.72±2%	41.94±2%	42.16±2%	42.41±2%	42.62±2%	42.78±2%	42.94±2%
Short circuit current Isc(A)	10.21±2%	10.28±2%	10.35±2%	10.44±2%	10.52±2%	10.59±2%	10.69±2%	10.78±2%
Max. power voltage Vmp(V)	33.23	33.47	33.67	33.91	34.17	34.40	34.62	34.84
Max. power current Imp(A)	9.63	9.71	9.80	9.88	9.95	10.03	10.11	10.19

ME445M6-144 / ME445M6B-144 Series:

Parameters	ME425M6-144/ ME425M6B-144	ME430M6-144/ ME430M6B-144	ME435M6-144/ ME435M6B-144	ME440M6-144/ ME440M6B-144	ME445M6-144/ ME445M6B-144	ME450M6-144/ ME450M6B-144	ME455M6-144/ ME455M6B-144
Peak power Pm(W)	425±3%	430±3%	435±3%	440±3%	445±3%	450±3%	455±3%
Open circuit voltage Voc(V)	48.49±2%	48.65±2%	48.84±2%	49.05±2%	49.28±2%	49.51±2%	49.75±2%
Short circuit current Isc(A)	11.41±2%	11.49±2%	11.57±2%	11.64±2%	11.71±2%	11.78±2%	11.84±2%
Max. power voltage Vmp(V)	40.51	40.72	40.88	41.08	41.28	41.47	41.70
Max. power current Imp(A)	10.49	10.56	10.64	10.71	10.78	10.85	10.91

E-mail: info@more-energy.net www.more-energy.net

Adresse: Fürtherstr. 38, 90429 Nürnberg, Germany

Hotline/WhatsApp: +49 15 225 20 30 30



ME405M6-132 / ME405M6B-132 Series:

Parameters	ME390M6-132/ ME390M6B-132	ME395M6-132/ ME395M6B-132	ME400M6-132/ ME400M6B-132	ME405M6-132/ ME405M6B-132	ME410M6-132/ ME410M6B-132	ME415M6-132/ ME415M6B-132
Peak power Pm(W)	390±3%	395±3%	400±3%	405±3%	410±3%	415±3%
Open circuit voltage Voc(V)	44.49±2%	44.65±2%	44.85±2%	45.06±2%	45.28±2%	45.46±2%
Short circuit current Isc(A)	11.41±2%	11.50±2%	11.59±2%	11.66±2%	11.74±2%	11.83±2%
Max. power voltage Vmp(V)	37.18	37.37	37.52	37.74	37.93	38.07
Max. power current Imp(A)	10.49	10.57	10.66	10.73	10.81	10.90

ME370M6-120 / ME370M6B-120 Series:

Parameters	ME355M6-120/ ME355M6B-120	ME360M6-120/ ME360M6B-120	ME365M6-120/ ME365M6B-120	ME370M6-120/ ME370M6B-120	ME375M6-120/ ME375M6B-120	ME380M6-120/ ME380M6B-120
Peak power Pm(W)	355±3%	360±3%	365±3%	370±3%	375±3%	380±3%
Open circuit voltage Voc(V)	40.46±2%	40.62±2%	40.83±2%	41.08±2%	41.28±2%	41.59±2%
Short circuit current Isc(A)	11.42±2%	11.53±2%	11.62±2%	11.70±2%	11.79±2%	11.85±2%
Max. power voltage Vmp(V)	33.81	33.96	34.14	34.35	34.53	34.80
Max. power current Imp(A)	10.50	10.60	10.69	10.77	10.86	10.92

E-mail: info@more-energy.net www.more-energy.net

Adresse: Fürtherstr. 38, 90429 Nürnberg, Germany

Hotline/WhatsApp: +49 15 225 20 30 30



ME540M10-144 / ME540M10B-144 Series:

Parameters	ME535M10-144/ ME535M10B-144	ME540M10-144/ ME540M10B-144	ME545M10-144/ ME545M10B-144	ME550M10-144/ ME550M10B-144
Peak power Pm(W)	535±3%	540±3%	545±3%	550±3%
Open circuit voltage Voc(V)	49.87±2%	49.95±2%	50.04±2%	50.28±2%
Short circuit current Isc(A)	13.72±2%	13.78±2%	13.84±2%	13.90±2%
Max. power voltage Vmp(V)	41.51	41.70	41.92	42.11
Max. power current Imp(A)	12.89	12.95	13.00	13.06

ME495M10-132 / ME495M10B-132 Series:

Parameters	ME490M10-132/ ME490M10B-132	ME495M10-132/ ME495M10B-132	ME500M10-132/ ME500M10B-132
Peak power Pm(W)	490±3%	495±3%	500±3%
Open circuit voltage Voc(V)	45.62±2%	45.87±2%	45.98±2%
Short circuit current Isc(A)	13.76±2%	13.81±2%	13.87±2%
Max. power voltage Vmp(V)	38.04	38.25	38.43
Max. power current Imp(A)	12.88	12.94	13.01

ME450M10-120 / ME450M10B-120 Series:

Parameters	ME445M10-120/ ME445M10B-120	ME450M10-120/ ME450M10B-120	ME455M10-120/ ME455M10B-120
Peak power Pm(W)	445±3%	450±3%	455±3%
Open circuit voltage Voc(V)	41.22±2%	41.48±2%	41.75±2%

E-mail: info@more-energy.net www.more-energy.net
 Adresse: Fürtherstr. 38, 90429 Nürnberg, Germany
 Hotline/WhatsApp: +49 15 225 20 30 30



Short circuit current Isc(A)	13.82±2%	13.88±2%	13.93±2%
Max. power voltage Vmp(V)	34.42	34.67	34.92
Max. power current Imp(A)	12.93	12.98	13.03

ME405M10-108 / ME405M10B-108 Series:

Parameters	ME400M10-108/ ME400M10B-108	ME405M10-108/ ME405M10B-108	ME410M10-108/ ME410M10B-108
Peak power Pm(W)	400±3%	405±3%	410±3%
Open circuit voltage Voc(V)	37.10±2%	37.33±2%	37.58±2%
Short circuit current Isc(A)	13.80±2%	13.87±2%	13.94±2%
Max. power voltage Vmp(V)	30.98	31.23	31.44
Max. power current Imp(A)	12.91	12.97	13.04

ME650G12-132 / ME650G12B-132 Series:

Parameters	ME635G12-132/ ME635G12B-132	ME640G12-132/ ME640G12B-132	ME645G12-132/ ME645G12B-132	ME650G12-132/ ME650G12B-132	ME655G12-132/ ME655G12B-132	ME660G12-132/ ME660G12B-132	ME665G12-132/ ME665G12B-132
Peak power Pm(W)	635±3%	640±3%	645±3%	650±3%	655±3%	660±3%	665±3%
Open circuit voltage Voc(V)	45.13±2%	45.30±2%	45.50±2%	45.68±2%	45.87±2%	46.03±2%	46.24±2%
Short circuit current Isc(A)	18.48±2%	18.53±2%	18.58±2%	18.63±2%	18.68±2%	18.73±2%	18.78±2%
Max. power voltage Vmp(V)	37.16	37.34	37.52	37.72	37.91	38.08	38.28
Max. power current Imp(A)	17.09	17.14	17.19	17.23	17.28	17.33	17.37

ME590G12-120 / ME590G12B-120 Series:

E-mail: info@more-energy.net www.more-energy.net
 Adresse: Fürtherstr. 38, 90429 Nürnberg, Germany
 Hotline/WhatsApp: +49 15 225 20 30 30



Parameters	ME580G12-120/ ME580G12B-120	ME585G12-120/ ME585G12B-120	ME590G12-120/ ME590G12B-120	ME595G12-120/ ME595G12B-120	ME600G12-120/ ME600G12B-120	ME605G12-120/ ME605G12B-120
Peak power Pm(W)	580±3%	585±3%	590±3%	595±3%	600±3%	605±3%
Open circuit voltage Voc(V)	41.04±2%	41.24±2%	41.44±2%	41.64±2%	41.84±2%	42.04±2%
Short circuit current Isc(A)	18.55±2%	18.60±2%	18.65±2%	18.70±2%	18.75±2%	18.80±2%
Max. power voltage Vmp(V)	33.76	33.95	34.14	34.35	34.54	34.75
Max. power current Imp(A)	17.18	17.23	17.28	17.32	17.37	17.41

ME530G12-108 / ME530G12B-108 Series:

Parameters	ME520G12-108/ ME520G12B-108	ME525G12-108/ ME525G12B-108	ME530G12-108/ ME530G12B-108	ME535G12-108/ ME535G12B-108	ME540G12-108/ ME540G12B-108	ME545G12-108/ ME545G12B-108
Peak power Pm(W)	520±3%	525±3%	530±3%	535±3%	540±3%	545±3%
Open circuit voltage Voc(V)	36.86±2%	37.08	37.27	37.45	37.64	37.84
Short circuit current Isc(A)	18.54±2%	18.59	18.66	18.72	18.78	18.82
Max. power voltage Vmp(V)	30.36	30.54	30.72	30.92	31.11	31.29
Max. power current Imp(A)	17.13	17.19	17.25	17.30	17.36	17.42

E-mail: info@more-energy.net www.more-energy.net

Adresse: Fürtherstr. 38, 90429 Nürnberg, Germany

Hotline/WhatsApp: +49 15 225 20 30 30



Company Name: More Energy GmbH

Add: Fuertherstr. 38, 90429 Nuremberg, Germany

E-mail:info@more-energy.net www.more-energy.net

Adresse:Fürtherstr. 38,90429 Nürnberg,Germany

Hotline/WhatsApp:+49 15 225 20 30 30

